

Typical Timber Frame Cons:
 100 Brick External Leaf
 60 Cavity
 Breather Membrane
 Dressed over D.P.C. on
 18 WBP Plywood with
 100x175 Timber Frame Inner leaf with
 100 Quilt Insulation
 Vapour Barrier on
 12.5 Internal Plasterboard

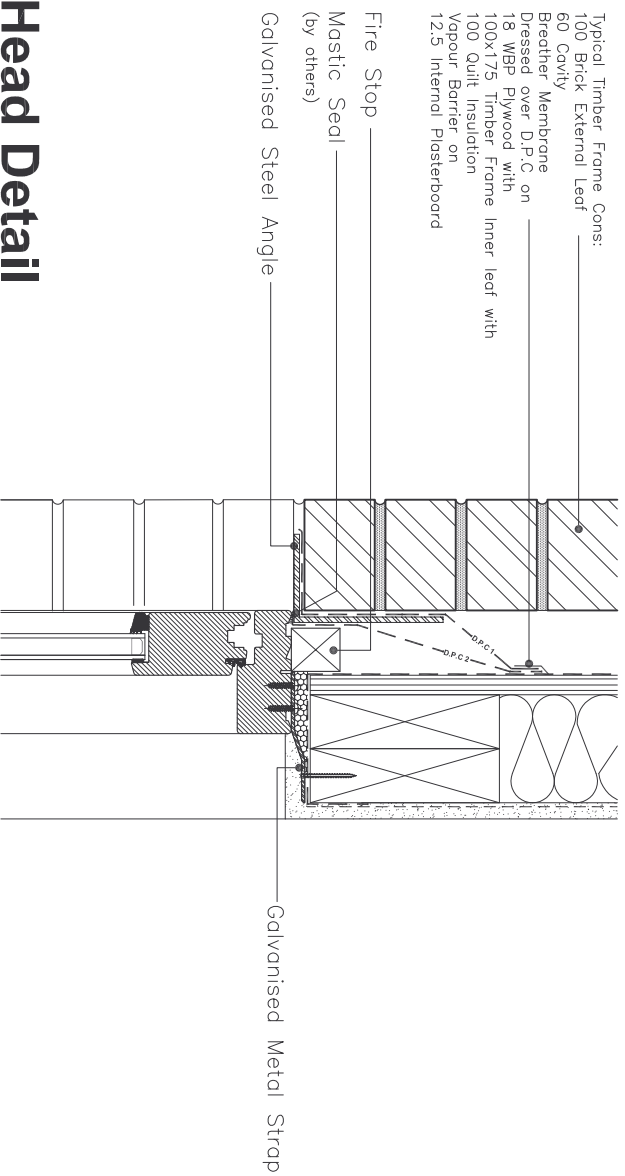

Head Detail

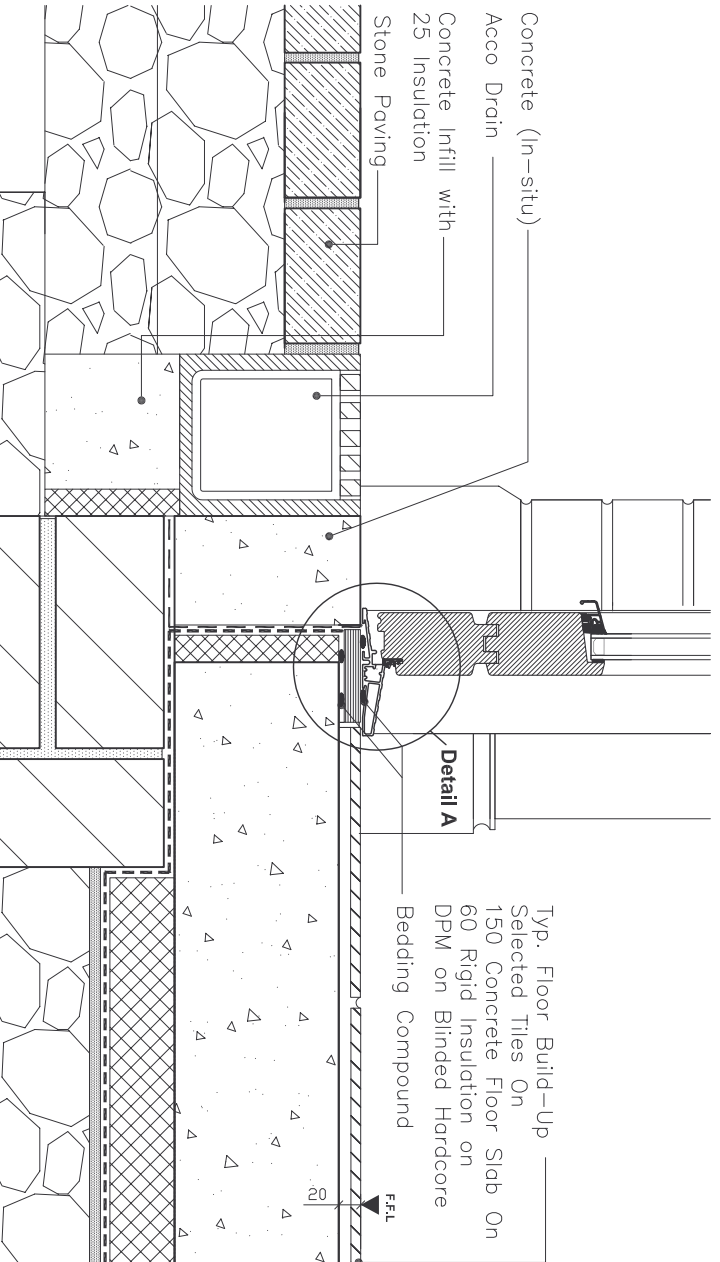

Low Level Alu. Threshold : Outward opening

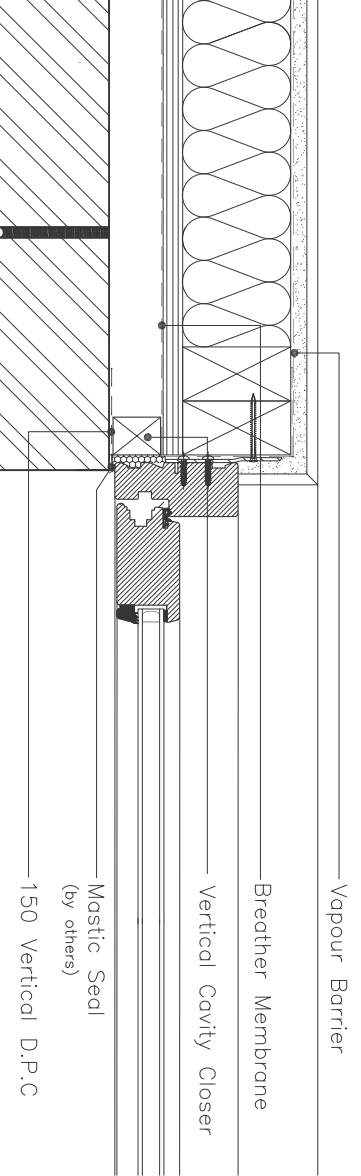

Jamb Detail

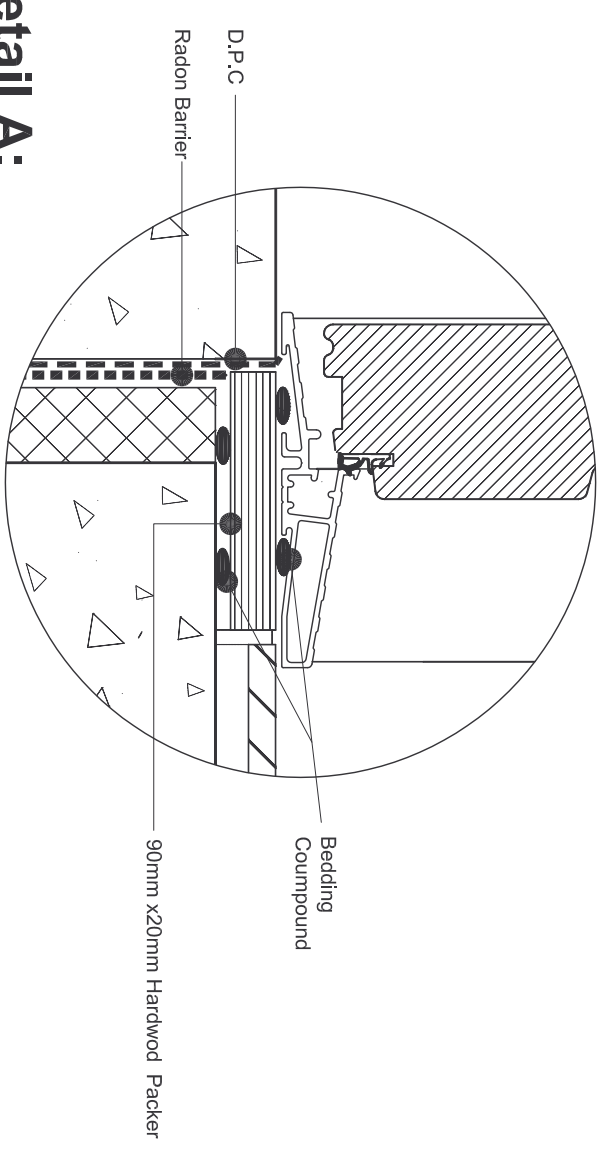

Detail A:

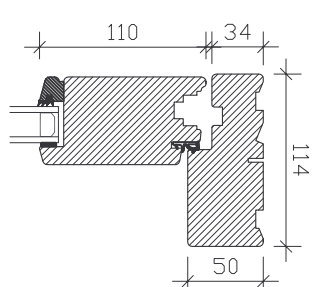

HEAD:
OPENING SASH

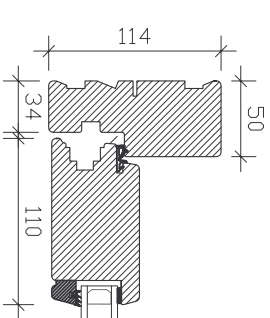

JAMB:
OPENING SASH

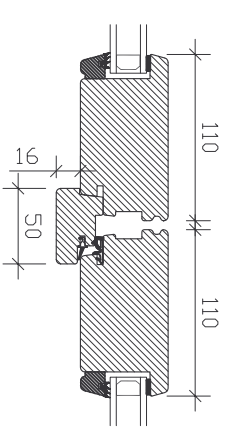

MULLION:
OPENING SASH

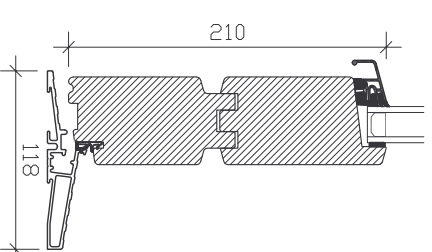

THRESHOLD:
LOW LEVEL ALU.
OPENING SASH

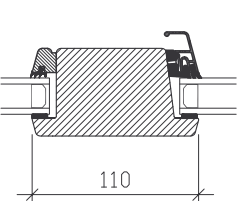

TRANSOM:
FIXED SASH

Profile Sections



CARLSON

G1, Calmount Park, Ballymount, D12
 TEL: 00 353 1 462 5777 FAX: 00 353 1 462 5737
 WEB: www.carlson.ie EMAIL: info@carlson.ie

DETAIL 153: TIMBER FRAME BRICKWORK